

Zivid 2⁺

MR60

Technical Specification

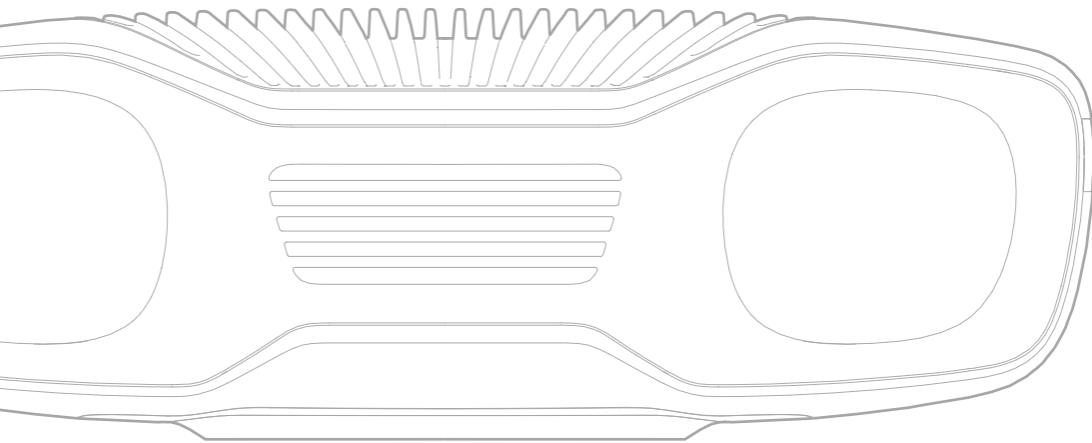

Introduction

Zivid 2+ is a product family of structured-light 3D cameras designed for machine vision applications. These cameras produce 2D color images and colored 3D point clouds with high resolution, fidelity and quality at high speeds ranging from 10's of milliseconds to seconds, depending on the application and required point cloud quality.

Zivid 2+ cameras are designed to be ruggedized and small, making them ideal for robot-mounted applications where the camera is fixed to the end-effector of a fast-moving robot. They are available in different variants with different field-of-view tailored to the volumes-of-interest of specific applications.

The Zivid 2+ cameras are designed for use in industrial environments and provide state-of-the-art performance and reliability. They are particularly suited to machine vision applications that require high-performance 3D imaging.

Overall, Zivid 2+ is an excellent choice for machine vision professionals who demand high-quality, flexible, and reliable 3D imaging.

Table of Contents

- Introduction 2
- Table of Contents 2
- General specifications 3
- Operating distance and field of view..... 4
- Accuracy specifications..... 9
 - Common conditions.....9
 - Typical specifications.....10
- Physical specifications 13
- Mechanical drawings..... 14
 - Connectors..... 16
 - Product Identification Label.....17
- Revision history 18

General specifications

Product	Zivid 2+ MR60
Model Number ¹	Z2+ MR60 (Zivid 2+ MR60)
Revision ²	Rev A0
Order code (default)	ZVD2P-MR60
3D technology	Structured light
Imaging	2448 x 2048 (5.0 MPx) Native 3D Color
Point cloud output	3D (XYZ) + Color (RGB) + SNR
Exposure time (minimum per pattern projection)	900 μ s
Aperture (A)	f/2.38 to f/16 (recommended)
Gain (G)	1x to 16x
Projector Brightness (B)	1.0x to 2.5x ³ (in 3D mode) 1.0x to 2.5x (in color 2D mode) 0.0x to 2.5x (in greyscale 2D mode) 1x = 360 lumens 2.5x = 900 lumens (max)
Calibration	Factory calibrated
Safety and EMC	CE CB EN62368 FCC Class B KC NRTL
Typical acquisition time ⁴	15 ms to 0.8 s
Typical capture time ⁵	30 ms to 1.0 s

¹ The model number is found on the physical label on the product and the box it was shipped in.

² The product's major revision of hardware for which this datasheet is valid. The revision can be found together with the model number (M/N) on the physical label of the product.

³ Limited to 2.2x when projecting white light unless "unlimited" is specified in config.yml.

⁴ Time for camera to illuminate and acquire all images used for 3D reconstruction.

⁵ From capture initialized until point cloud is ready to copy. Includes processing. Acquisition time can be shorter.

Operating distance and field of view

Focus distance (mm)	600
Optimal working distance (mm)	350 to 900
Recommended working distance (mm)	300 to 1100
Field of view (mm)	570 x 460 at 600
Spatial resolution (mm)	0.24 at 600 4.07 × 10 ⁻⁴ per distance (z) in mm

FIGURE 1 – FIELD OF VIEW

All values in degrees or mm.

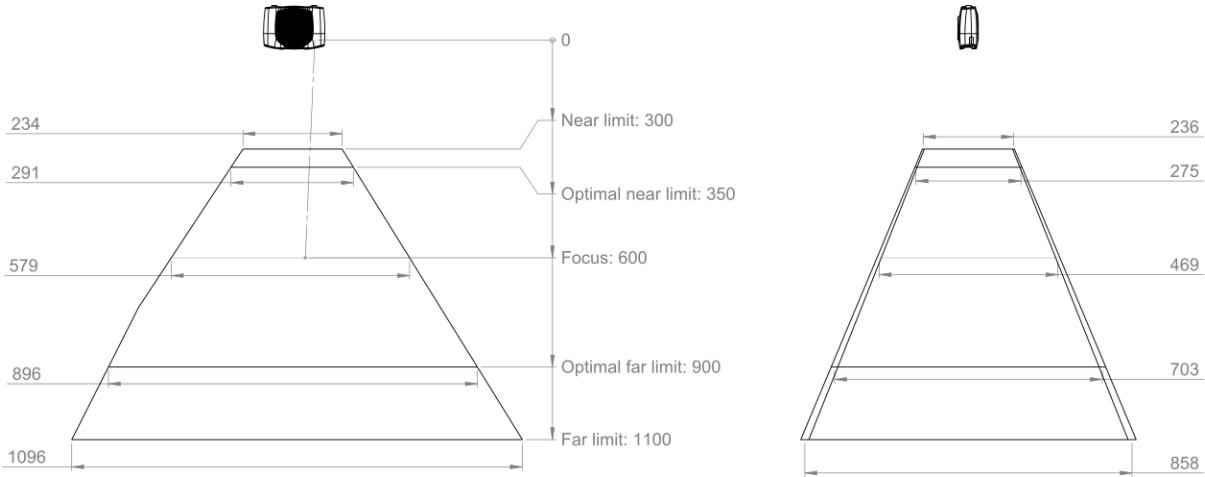

FIGURE 2 – FIELD OF VIEW vs. DISTANCE

All values in degrees or mm.

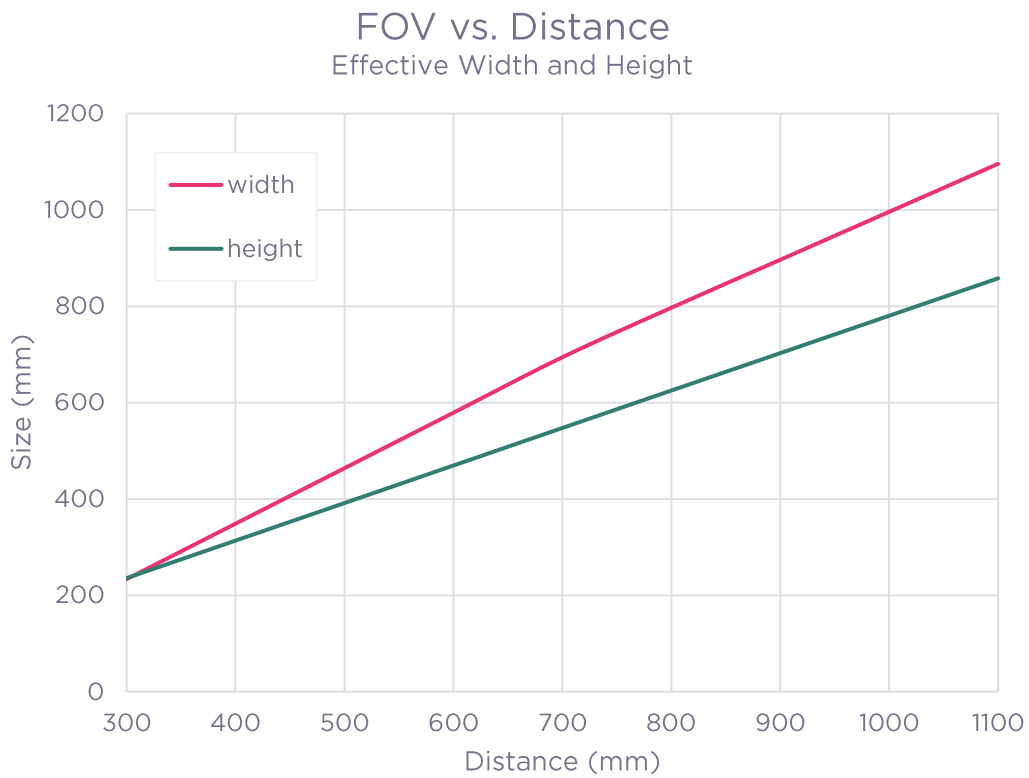

FIGURE 3 – SPATIAL RESOLUTION

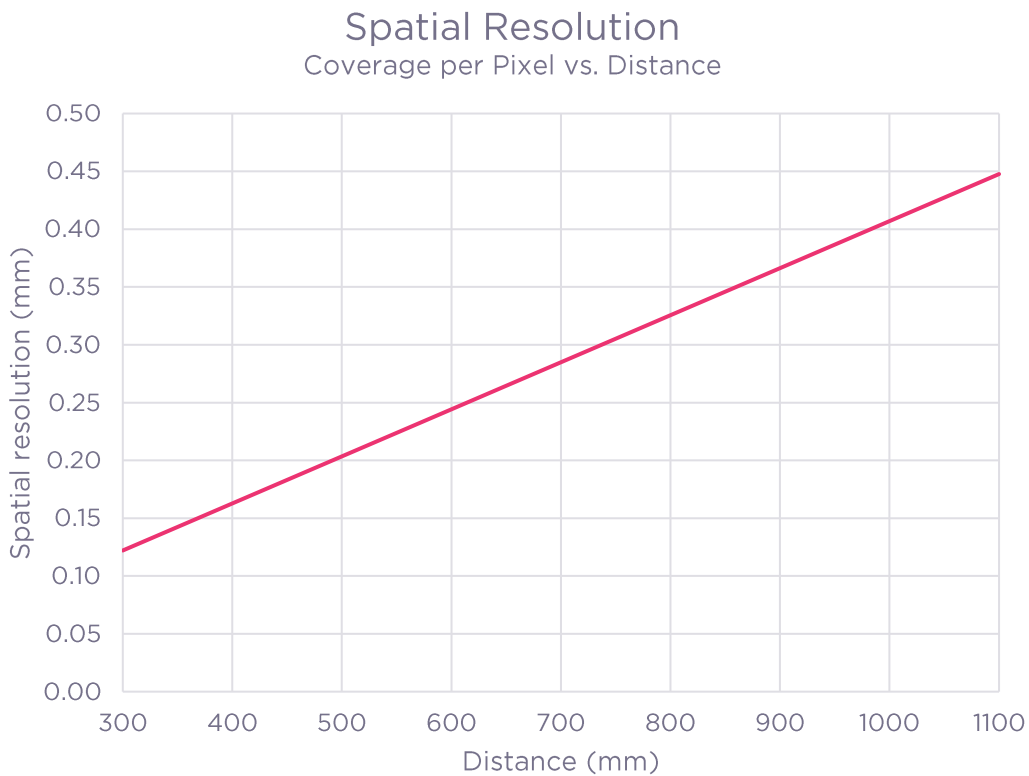

FIGURE 4 – PROJECTOR BRIGHTNESS

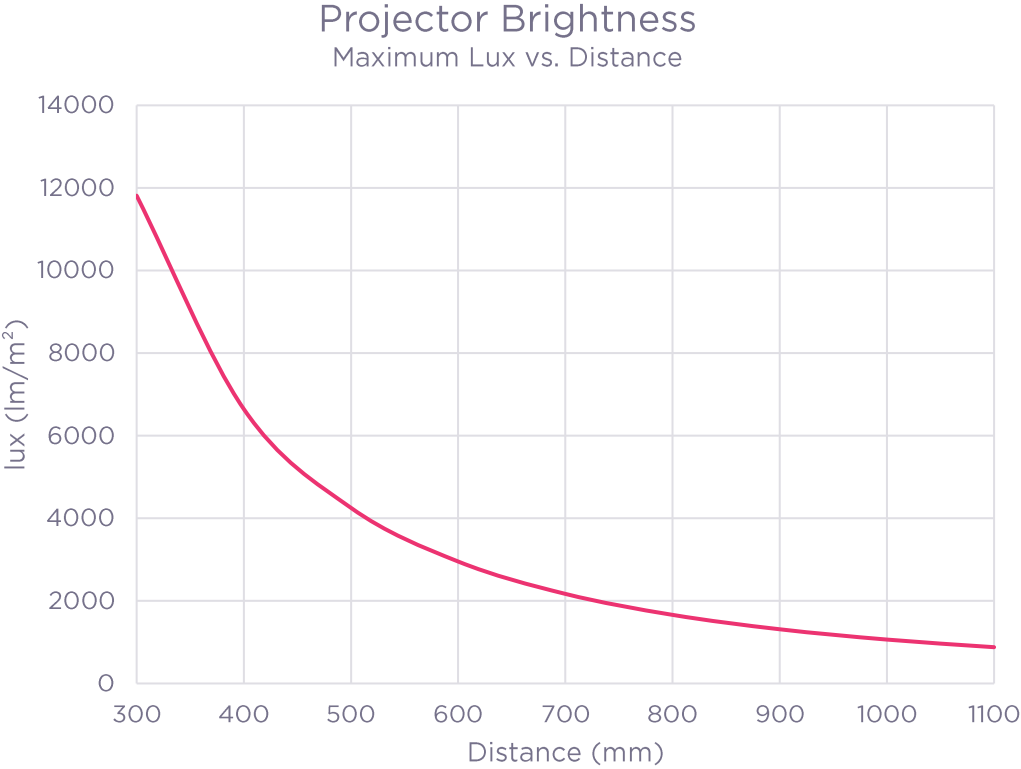

FIGURE 5 - OPTICAL ANGLES AND BASELINE

All values in degrees or mm.

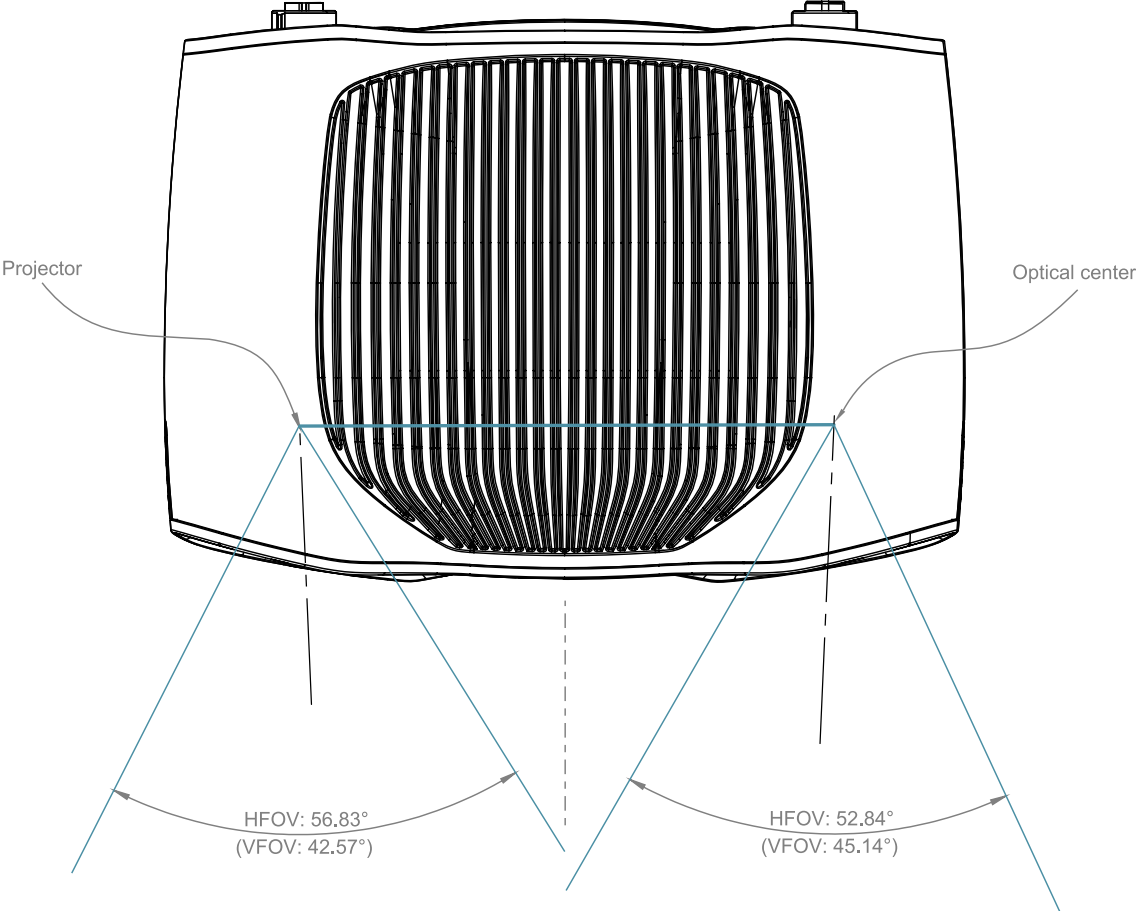

FIGURE 6 - OPTICAL CENTER POSITION RELATIVE TO MOUNTING HOLES

All values in degrees or mm.

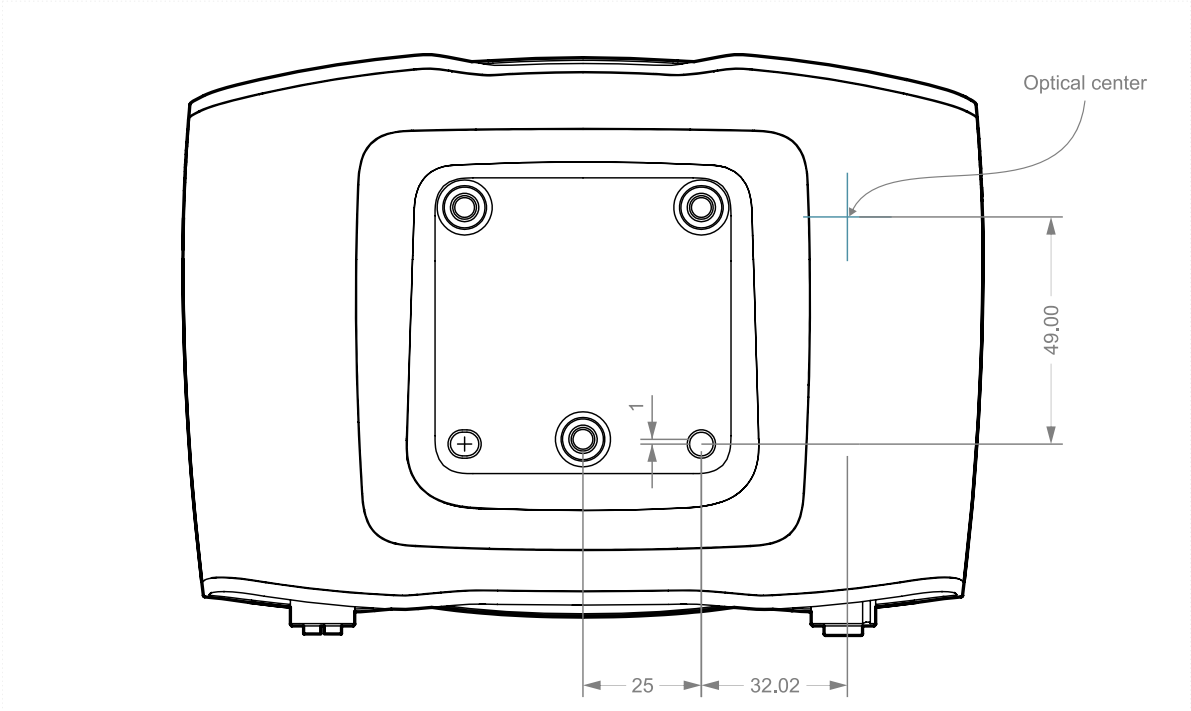
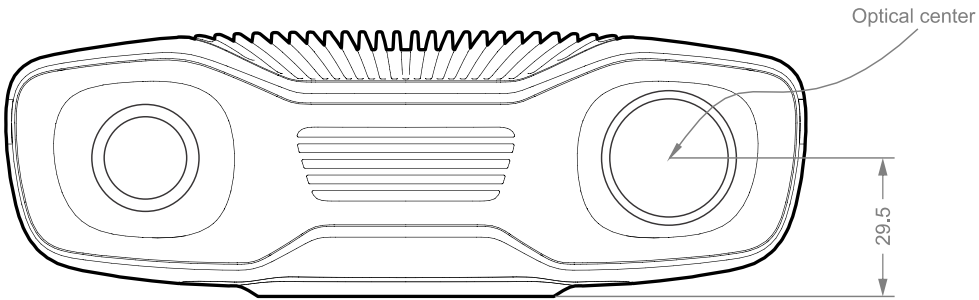

FIGURE 7 - OPTICAL CENTER POSITION RELATIVE TO BASE PLATE

All values in degrees or mm.



Accuracy specifications

Common conditions

The following table outlines the conditions applied under test and to all specifications unless stated otherwise.

Parameter	Description	Typical
Working distance (D)	Focus distance	600 mm
	Optimal working distance	350 - 900 mm
Ambient temperature (Ta)	Typical temperature	15 - 30 °C
	Full temperature range	0 - 40 °C
Ambient light (La)		0 lux
Aperture (A)		f/8.0 - f/2.38
Gain (G)		1.0 x
Projector Brightness (B)		1.0 - 2.5 x
3D Engine	3D engine (reconstruction algorithm) used during measurement	Phase, Stripe
Sampling mode	Sampling mode for sensor pixels used during measurement	All pixels sampled
Capture time	Acquisition time used during measurement	> 15 ms
	Capture time used during measurement	> 25 ms
Duty Cycle	Capture-to-Idle time ratio	5 - 30 %
Other		81% center crop (90% × 90%) HDR = off (single acquisition only) 10 min warm-up Applied in-field correction

Typical specifications

Typical numbers are given at common conditions unless otherwise specified.

Property	Description	Typical
Warm-up time	The minimum recommended time needed for camera to stabilize from an idle state assuming capturing at a constant rate. ⁶	10 minutes
Dynamic Range	Maximum for 1-frame acquisition, Phase engine	74 dB
	Maximum for 1-frame acquisition, Omni engine	86 dB
	Maximum for HDR acquisition	129 dB
Point precision	1σ Euclidian distance variation for a point between consecutive measurements at focus distance, D. ⁷	80 μ m
Local Planarity Precision	1σ Euclidian distance variation from a plane for a set of points within a smaller local region at focus distance, D. ^{8 10}	100 μ m
Global Planarity Trueness Error	Average deviation from a plane in field of view at focus distance, D. ^{9 10}	< 0.10 mm
Dimension Trueness Error	70-percentile dimension error in field of view at focus distance, D, and typical temperature range. ¹¹	< 0.20 %
	70-percentile dimension error in field of view within optimal working distance and typical temperature range. ¹¹	< 0.25 %
	70-percentile dimension error in field of view within optimal working distance and full temperature range. ¹¹	< 0.35 %

Note: The term “accuracy” is composed of a precision component and a trueness component as described in ISO 5725.

⁶ Some trueness changes may be experienced during warm-up phase.

⁷ Point precision is found by measuring an individual point's capture-to-capture variation in space for all points in the point cloud over multiple consecutive measurements.

⁸ Local planarity precision is defined as the average standard deviation of all individual local standard deviations across the entire field-of-view. An individual local standard deviation is found by measuring the orthogonal distance from a fitted plane of all individual points within a small local region, e.g., 50 by 50 pixels.

⁹ Global planarity trueness error is found by measuring the distance of all individual points in the point cloud from a flat reference surface. Can also be interpreted as flatness.

¹⁰ Measured using the unfiltered, raw output of a single-acquisition 3D capture on a Lambertian surface. Enabling post processing filters, such as Gaussian filter, can further suppress noise to great effect.

¹¹ Dimension trueness error is found by measuring the error of multiple calibrated reference distances in the point cloud. A reference distance can be 5 to 50 cm. The calibrated reference object is measured repeatedly across the entire field of view and operating distance, and during exposure of thermal and mechanical stress, such as temperature change, vibration, and shock.

FIGURE 8 - POINT PRECISION VS. DISTANCE AND AMBIENT LIGHT

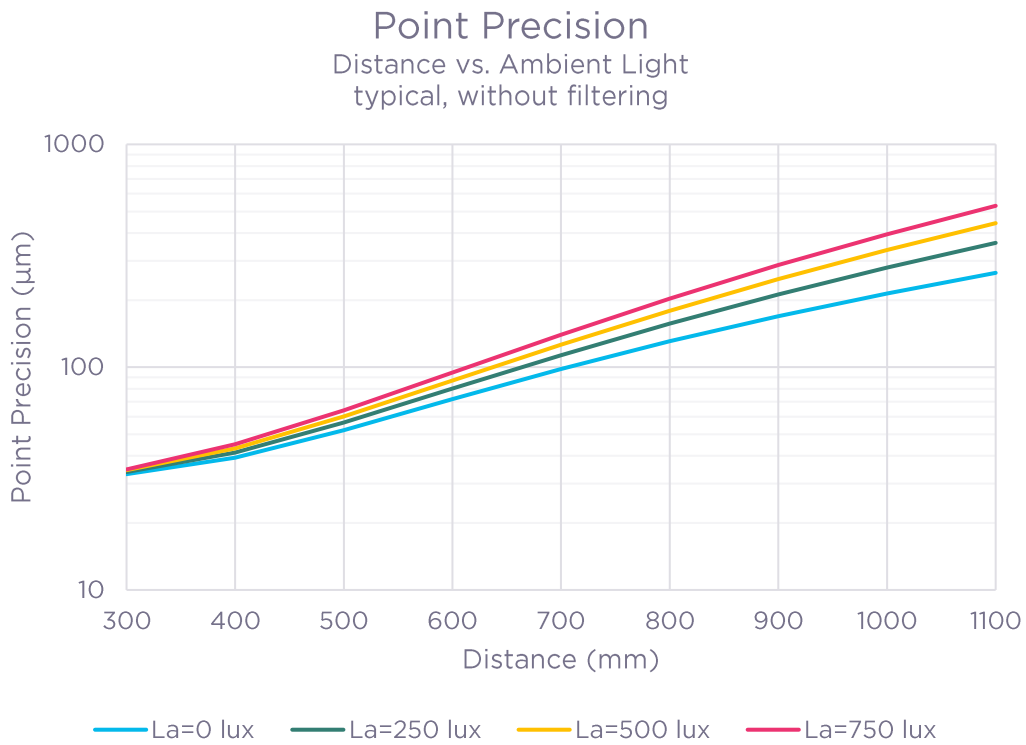

FIGURE 9 - LOCAL PLANARITY PRECISION VS. DISTANCE

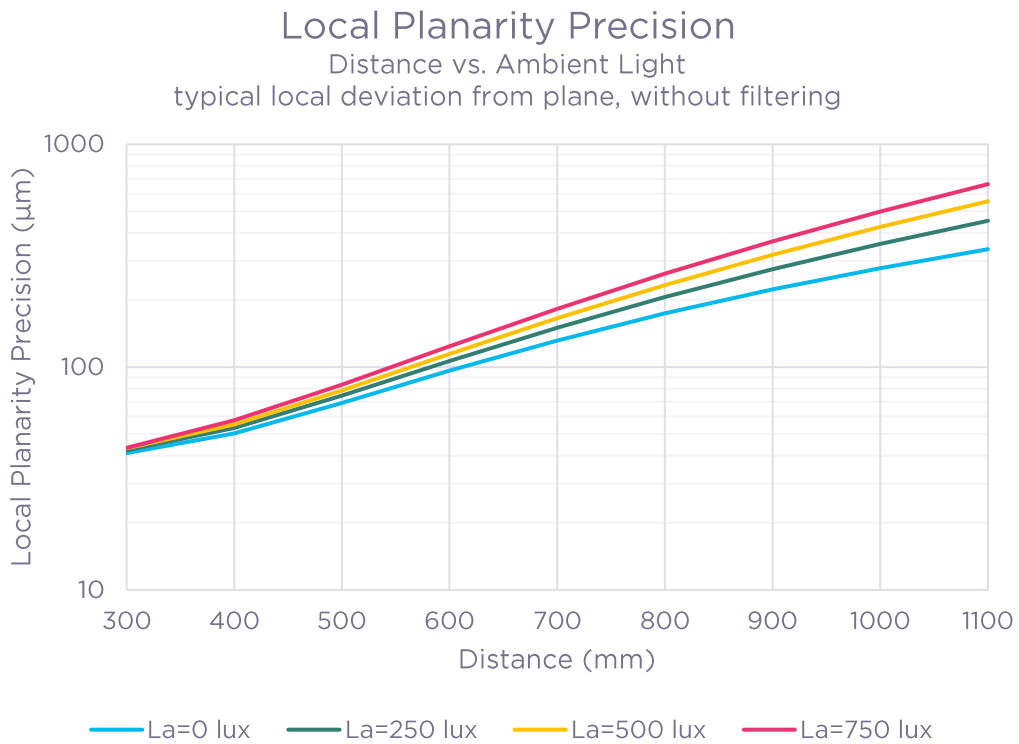

FIGURE 10 - GLOBAL PLANARITY TRUENESS VS. DISTANCE

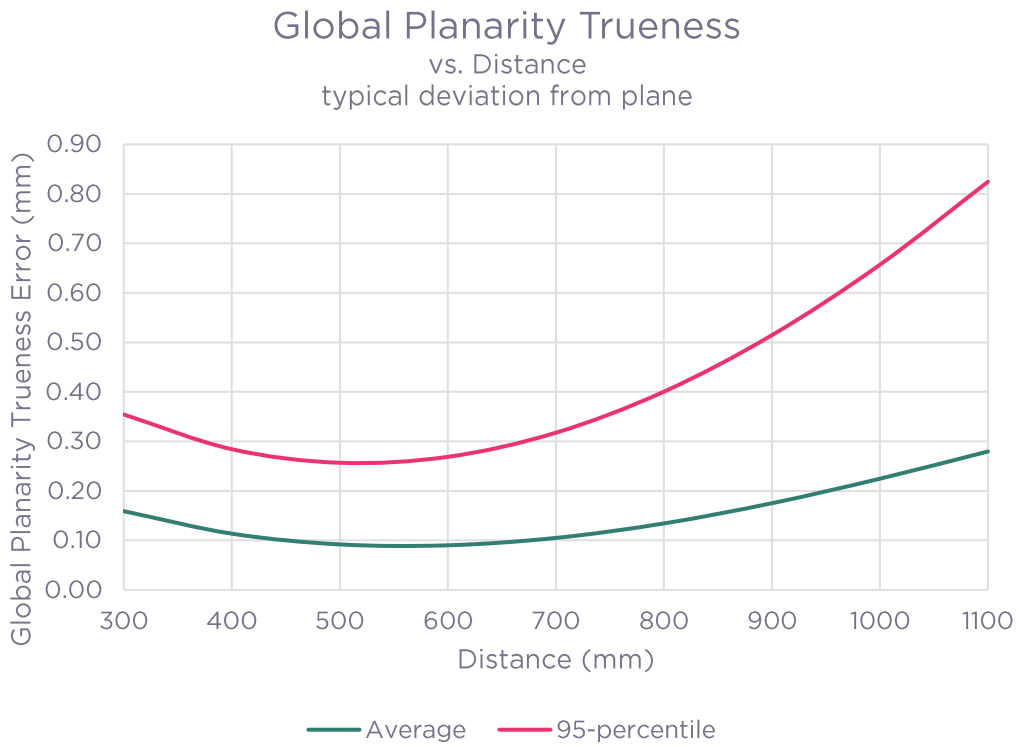
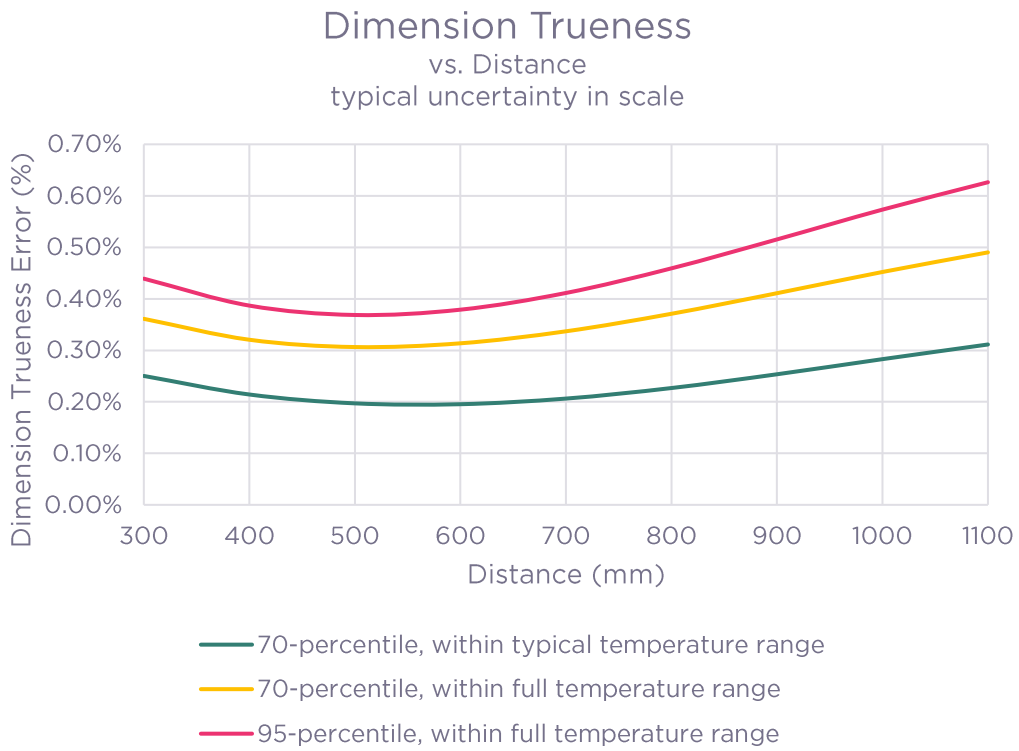

FIGURE 11 - DIMENSION TRUENESS VS. DISTANCE



Physical specifications

Size	169 mm x 124 mm x 56 mm
Weight	1000 g
Flatness tolerance of mounting surface ¹²	±0.05 mm
Cable strain limit	125 N
Environmental	IP65 5 g sinusoidal ¹³ 15 g shock ¹⁴
Operating temperature	0° to 40° C
Storage temperature	-20° to 60° C
Humidity ¹⁵	10 – 90 %, non-condensing
Safety ¹⁶	RG2
Noise, typical at 1 m distance	< 28 dB, typical use 67 dB, at maximum fan speed
Data connection	10 GigE ¹⁷ M12 X-coded, 8-pin connector CAT6A, SF-UTP or better
Power connection	M12-5
Power adapter	24 V = 5A, DC EU, US, and UK power plug options
Power consumption, typical	15 W, Idle 45 W, TDP ¹⁸ 100 (120) W, Peak ¹⁹

¹² The surface which the camera is mounted to should meet this specification.

¹³ IEC 60068-2-6, 10-150 Hz, 5 g, in X, Y and Z direction, 2 hour per axis. Sweep rate 1 octave per minute sweep rate.

¹⁴ IEC 60068-2-27, 15 g / 11 ms half sine shock pulses. 3 shocks per direction, 18 shocks in total.

¹⁵ Relative humidity during operation and storage.

¹⁶ IEC 62471, photobiological (eye) safety of LED. EN 62471:2015. IEC/TR 62471-5.

¹⁷ Slower gigabit ethernet connections, such as 1 GigE, also supported, but can reduce capture speed.

¹⁸ Thermal Design Power is the maximum power consumed while capturing 3D images in a continuous stream.

¹⁹ Compatible with Class 2 circuit breakers per NEC standards under normal use; non-compatibility may occur with projector brightness >2.2 while projecting white light.

Mechanical Installation

3 x M5x0.8 screws.

Depth: 5-7 mm

Max torque: 3 Nm

Mechanical drawings

FIGURE 12 - DIMENSIONS

All values in degrees or mm.

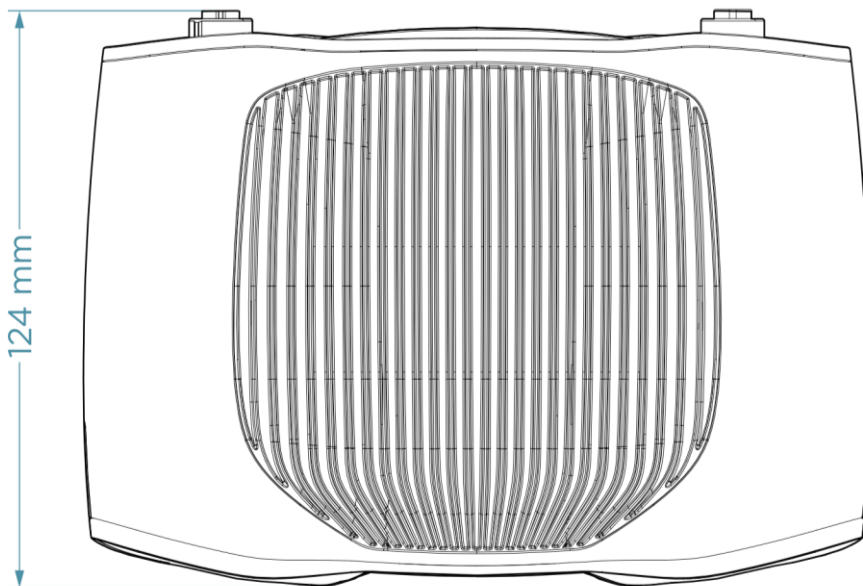
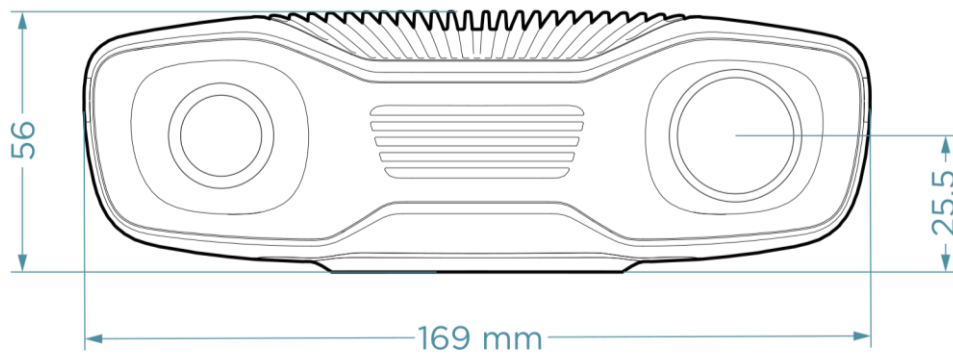
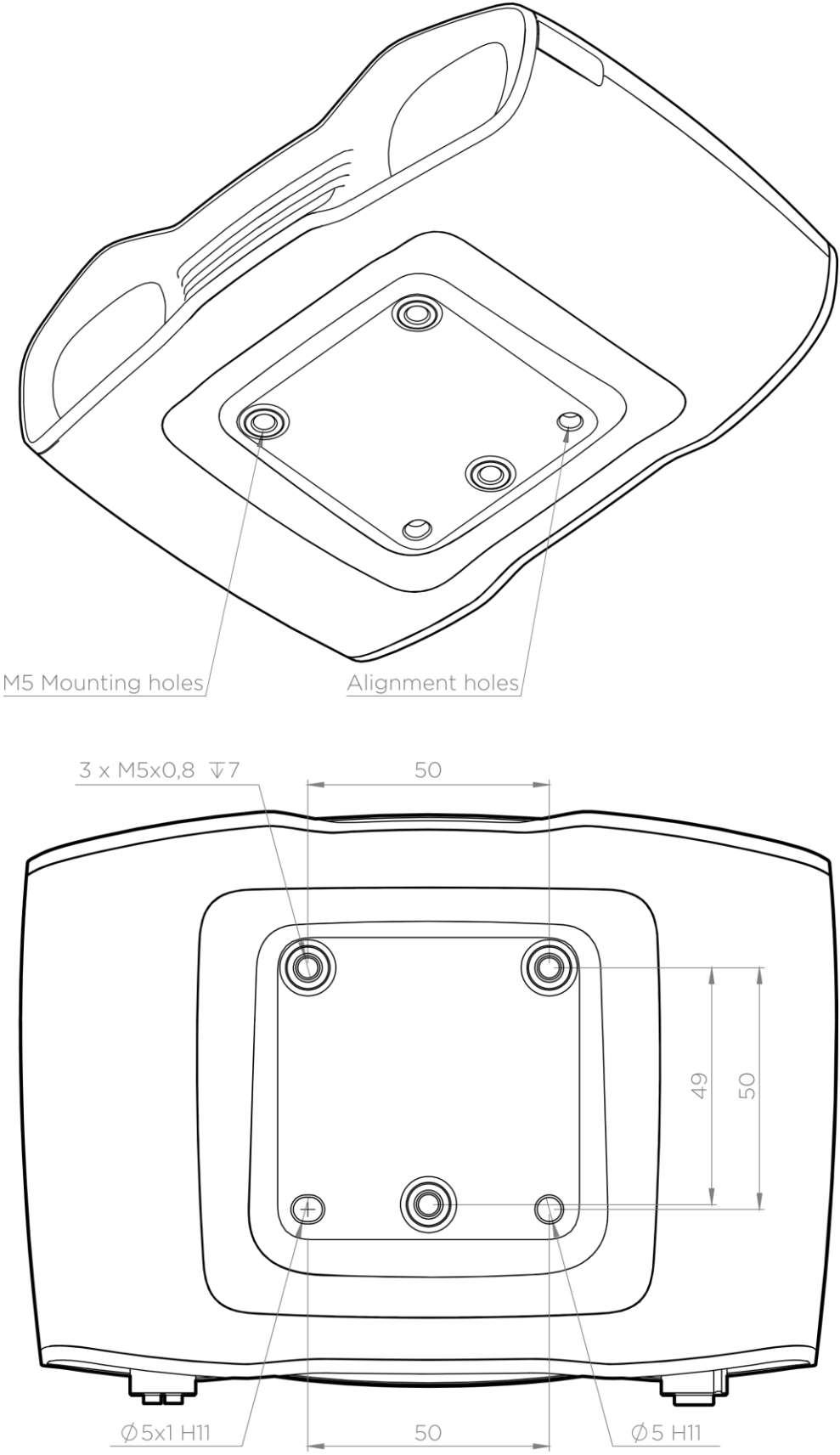

FIGURE 13 – MOUNTING OPTIONS

All values in degrees or mm.



Connectors

FIGURE 14 - CONNECTORS

All values in degrees or mm.

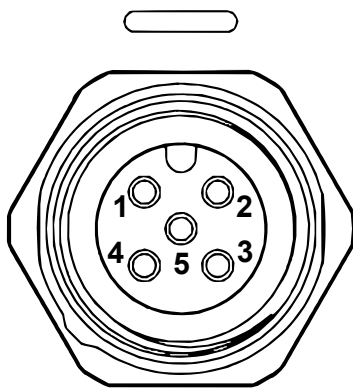
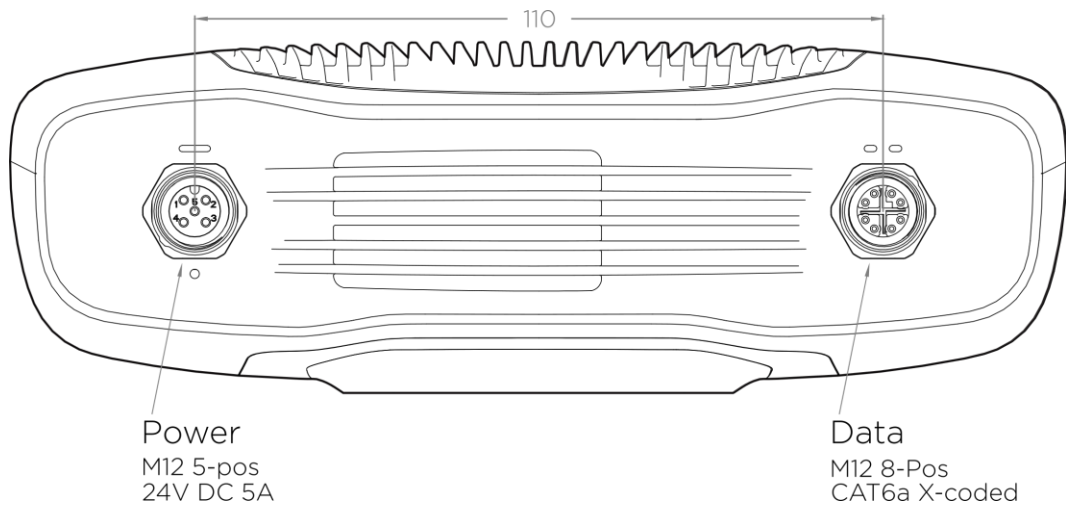

Pin #	M12-5
1	24V DC (+10% / -20%)
2	24V DC (+10% / -20%)
3	GND
4	GND
5	NC ²⁰

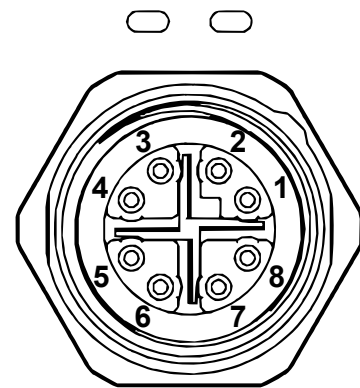

M12-X	RJ45	Color
1	1	WH/OG
2	2	OG
3	3	WH/GN
4	6	GN
5	7	WH/BN
6	8	BN
7	5	WH/BU
8	4	BU

²⁰ Not connected. Do not connect.

Product Identification Label

FIGURE 15 - PRODUCT LABEL

The product identification label is found on the bottom of the device. The label includes UID label (described in Figure 16 - Unique ID Label Explanation), IP rating, input power rating, eye safety rating, country of origin, NRTL, CE, UKCA, FCC and CAN-ICES.

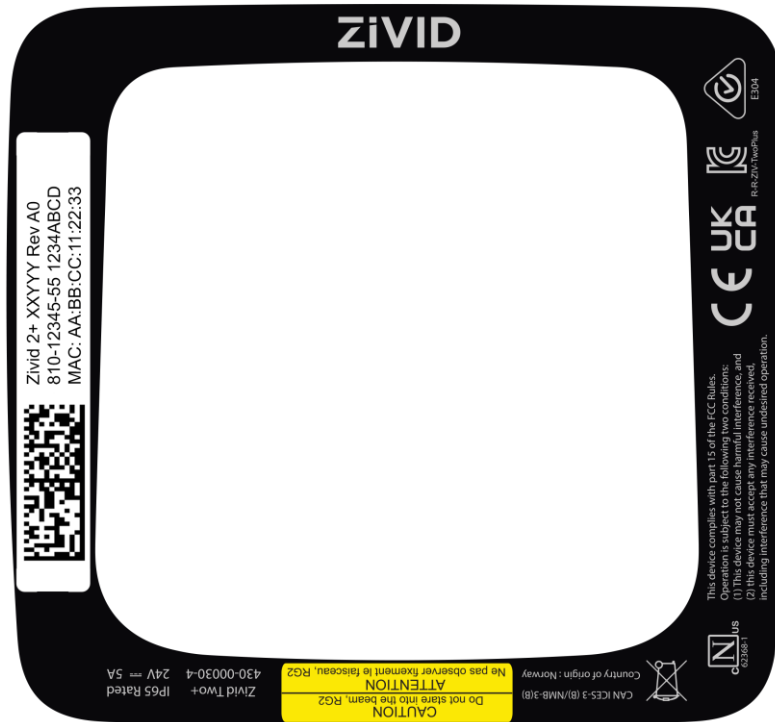

FIGURE 16 - UNIQUE ID LABEL EXPLANATION



1	2D code format: SKU, Revision and Serial, delimited by '\$': i.e. ZVD2P-M130\$A1\$1234ABCD
2	Product name
3	Product revision
4	Zivid part number and revision
5	Serial Number
6	MAC-address

Revision history

Ver.	Date	Notes
1.0	3/24	Initial version.
1.1	10/24	Added NRTL certification, mechanical installation specifications, and product identification label information.
1.2	11/24	Updated general specification values for brightness and exposure time.

Zivid AS
Gjerdrums vei 10A
N0484 Oslo
Norway

© 2023 Zivid AS. All rights reserved. Subject to change without notice.